



HOUSE WRAPS, TAPES, AND FLASHING.

INSTALLATION GUIDE



TABLE OF CONTENTS

PRODUCTS & SPECIFICATIONS

- 2** BARRICADE® PRODUCTS
- 3** PRODUCT SPECIFICATIONS

HOUSE WRAP

- 4** INSTALLATION

FLASHING TAPE

- 5** INSTALLATION
- 7** FLASHING CORNERS
- 8-9** FLASHING PENETRATIONS

OTHER

- 10** OTHER DETAILS

BARRICADE® PRODUCTS

HOUSE WRAPS



BARRICADE® WRAP

An economical builder-grade perforated wrap. Produced in our Virginia plant so it can meet our high-quality control standards.



BARRICADE® WRAP PLUS

A high-performance, non-perforated, non-woven permeable membrane. Building wraps made of non-perforated membranes offer the highest level of performance against wind, air, and moisture.



BARRICADE® R-WRAP®

A high-perm, non-perforated, non-woven permeable membrane. Building wraps made of non-perforated membranes offer the highest level of performance against wind, air, and moisture.

FLASHING



BARRICADE® FLASH RIGHT

A high-performance, asphalt-based window and door flashing tape designed to provide a permanent, weather-tight seal to protect from moisture, leaks, and air penetration.



BARRICADE® FLASH ULTI

Our top-of-the-line flashing tape offers the ultimate protection for windows and doors. The 100% butyl rubber adhesive creates a permanent, flexible, weatherproof seal, while the UV inhibitors protect against the sun's harmful rays.



BARRICADE® FLASH CONFORM

A highly stretchable flashing tape with an aggressive, slower-acting butyl rubber adhesive that conforms around radii and corners while providing maximum protection from water intrusion.



BARRICADE® FLASH EXTREME

Extremely aggressive, self-adhering flashing membrane designed to protect windows and doors from moisture penetration.



BARRICADE® FLASH CORNERS

Pre-cut Barricade Sill Corners provide a quick, easy, and economical seal at transitions between building envelope components.

ADDITIONAL MATERIALS



BARRICADE® SEAM TAPE

A thin, strong film-coated tape with a cold-weather adhesive system for added protection against energy-robbing air infiltration and exterior moisture penetration.



BARRICADE® BEAR CAULK

The perfect partner to Barricade tapes — a flexible, waterproof, door and window caulk for framework and joints.

SPECIFICATION OVERVIEW

	Construction Special Institute Identification Codes	Composition	Standard Sizes		Optional Sizes	Permeability (ASTM E-96A)	Tensile Strength	Flame Spread (ASTM E-84)	UV Exposure Rating	Applicable Standards	Warranty
BARRICADE® WRAP	Air Barriers – 07270	Perforated woven polyolefin	108" x 100' 108" x 150' 108" x 195'	120" x 100' 120" x 150' 120" x 195'	54" x 100' 54" x 150' 36" x 150'	11 US Perms	ASTM D-882 63.3 lbs/in. MD 51.4 lbs/in. CD	Class A	12 months	Manufactured to meet the full intent of all major building codes. Meets Fed. Spec. UU-B-790a Grade D	10-Year Limited System Warranty
BARRICADE® WRAP PLUS	Air Barriers – 07270	Non-perforated non-woven polyolefin	108" x 100' 108" x 150' 108" x 195'	120" x 100' 120" x 150' 120" x 195'	54" x 100' 54" x 150' 36" x 150'	16 US Perms	ASTM D-5034 59 lbs/in. MD 51 lbs/in. CD	Class A	9 months	Manufactured to meet the full intent of all major building codes. Meets Fed. Spec. UU-B-790a Grade D	10-Year Limited System Warranty
BARRICADE® R-WRAP®	Air Barriers – 07270	Non-perforated non-woven polyolefin	108" x 100' 108" x 150' 108" x 195'	120" x 100' 120" x 150' 120" x 195'	54" x 100' 54" x 150' 36" x 150'	50 US Perms	ASTM D-5034 59 lbs/in. MD 51 lbs/in. CD	Class A	9 months	Manufactured to meet the full intent of all major building codes. Meets Fed. Spec. UU-B-790a Grade D	10-Year Limited System Warranty

	Composition	Roll Length	Roll Widths	Rolls Per Case	Total Thickness	Tensile Strength	Application Temperature Range	Operating Temperature Range	Warranty	Nail Sealability	Shelf Life	UV Exposure Rating
BARRICADE® FLASH ULTI	Polyolefin faced, peel-and-stick flashing tape using butyl rubber adhesive	75'	4" 6" 9" 12" 18"	6 6 3 4 1	20 mils	60 lb/in	30°F–150°F	-30°F–200°F	10-Year Limited Warranty	Pass	12 Months	Up to 365 days
BARRICADE® FLASH CONFORM	Polyolefin film backing, butyl-based adhesive, polyethylene liner	75'	6" 8"	1	50 mils	> 400psi	40°F–180°F	-30°F–200°F	10-Year Limited Warranty	Pass	12 Months	Up to 365 days
BARRICADE® FLASH RIGHT	White polyolefin-faced, using SBS asphalt adhesive	75'	4" 6" 9" 12" 18"	9 6 4 3 2	20 mils	12 lb/in (ASTM D412)	40°F–160°F		10-Year Limited Warranty	Pass	12 Months	180 days
BARRICADE® FLASH EXTREME	Non-asphaltic, white polyolefin-faced flashing tape using pressure-sensitive adhesive	75'	4" 6" 9" 12"	12 8 4 4	15 mils		-30°F–150°F		10-Year Limited Warranty	Pass	18 Months	180 days
BARRICADE® FLASH CORNERS	Non-asphaltic, white polyolefin-faced flashing tape using pressure-sensitive adhesive	N/A	N/A	N/A	15 mils		-10°F–200°F		10-Year Limited Warranty	Pass	12 Months	180 days
BARRICADE® SEAM TAPE	Polypropylene film coated with a cold-weather acrylic adhesive system	165'	1 7/8" 3"	16	3 mils	20 lb/in	-10°F–200°F	-20°F–275°F	10-Year Limited Warranty	Pass	12 Months	180 days
BARRICADE® BEAR CAULK	One-component, solvent-free Silyl Modified Polyether (hybrid) sealant	N/A	N/A	24	N/A	N/A	N/A	N/A	1-year Limited Warranty	Pass	12 Months	

HOUSE WRAP INSTALLATION

FOR
BARRICADE® WRAP
BARRICADE® WRAP PLUS
BARRICADE® R-WRAP®

CONSIDERATIONS

Barricade wrap can be installed over wood-based, foam insulative, or fiberboard sheathing and exterior gypsum board.

Install building wrap in “shingle-lap” fashion, with the higher piece lapped over the outside of the piece below.

All horizontal overlaps of building wrap must be at least 2" (4" is recommended) and vertical overlaps must be at least 6".

At roof sections, be careful to lap the building wrap over the entire top of any step flashed areas against the wall.

We recommend using Barricade flashing products or an alternative that meets or exceeds Federal Specification UU-B-790a, Grade A and is minimum 6" in width.

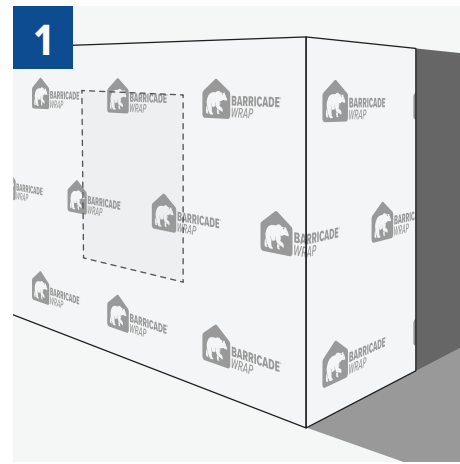

Start by placing the roll 2-3' (feet) from the corner and fasten using staples, large-headed nails, or roofing nails spaced a maximum of 18" (inches) on center.

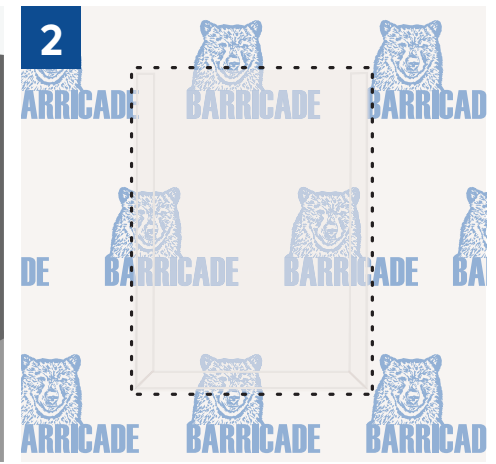

Unroll the wrap around the building and fasten with nails or staples, spaced a maximum of 32" on center.

When used over foam insulation boards, the sheet must be fastened with roofing nails or other large-headed nails long enough to penetrate through the insulation, into the framing studs.

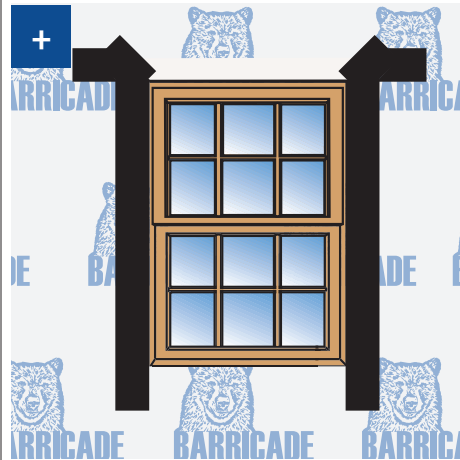

BARRICADE® BUILDING WRAP APPLICATION WITH EXISTING WINDOWS

1. Create a top flap so that the head flashing can be installed under the wrap and over the flange.
2. Leave the bottom unflashed, allowing moisture to escape.
3. On both sides, trim the wrap close to the window flange and secure it to the flange with tape or caulk, then install side flashing.
4. Install head flashing and extend out 3-4" to each side, then tape flap over.

(Note: Tape and caulk should only be used for securing purposes and should not be used as primary flashing material.)

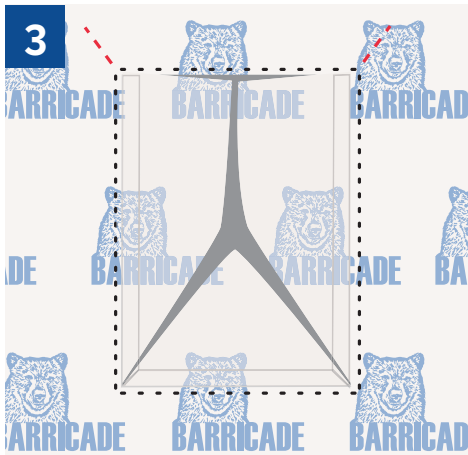

Make an inverted Y-cut in the wrap at window rough opening. Make diagonal cuts at the top of the rough opening. Windows must be installed according to the manufacturer's recommended installation process.

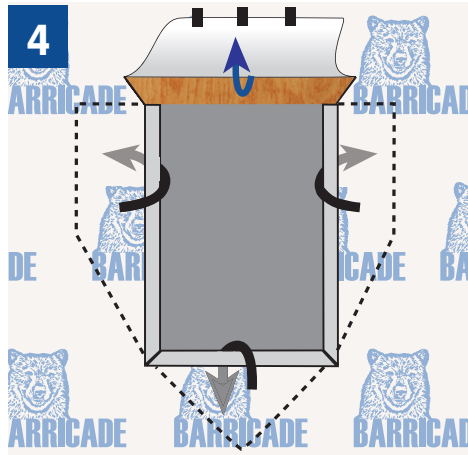

Fold the three flaps in through the opening, fastening them inside with staples set about every 6". Fold top flap up and tape temporarily as shown. Proceed to flashing installation (page 5).

FLASHING TAPE INSTALLATION

FOR
 BARRICADE® FLASH RIGHT
 BARRICADE® FLASH ULTI
 BARRICADE® FLASH CONFORM
 BARRICADE® FLASH EXTREME

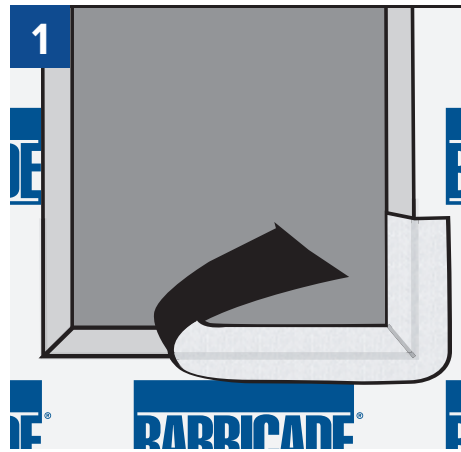

BARRICADE® FLASHING

Prepare sill flashing by cutting Barricade Flash Conform at least 12" longer than the width of the rough opening. Install sill flashing by removing the release paper, centering sill flashing on sill framing stud, and adhering into rough opening. The back edge of Flash Conform should extend to inside edge of sill framing stud and at least 6" up each jamb framing stud. (Sill flashing should not wrap onto the inside of wall.) DO NOT stretch material along the sill or jamb. When house wrap or conventional building paper is used as a weather-resistive barrier (WRB) over wall sheathing prior to window and flashing installation, Flash Conform should be applied over the WRB after it has been properly cut and folded in and around the window rough opening.



NOTE:

If a WRB will be applied after the window and flashing have already been installed, be sure not to fasten the lower edge of the flashing so that the WRB may be slipped underneath the flashing in weatherboard or shingle lap fashion (i.e., top layer overlapping bottom layer).

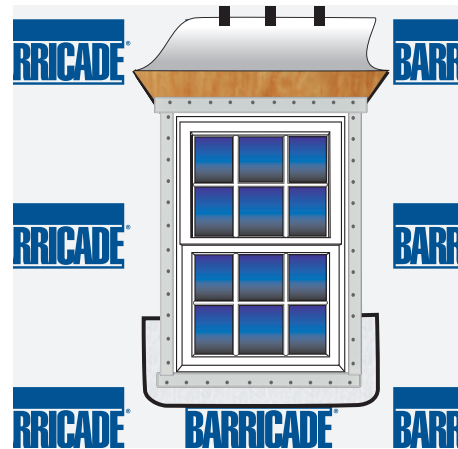
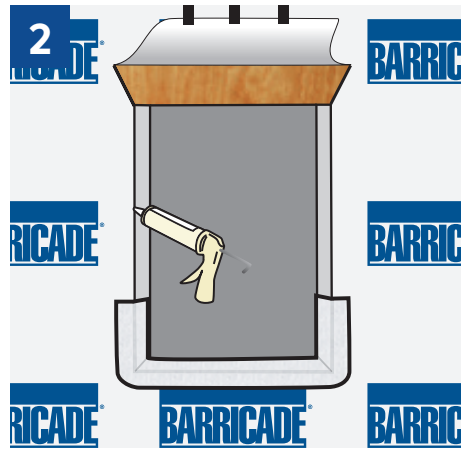

WINDOW AND DOOR INSTALLATION

Before installing the window, either (A) apply a continuous bead of sealant to the backside (interior) of the mounting flange near the outer edge, or (B) apply a continuous seal to the rough window opening at a point to assure contact with the backside (interior) of the mounting flange. DO NOT caulk along bottom. Install window according to manufacturer's installation procedures. Use of Barricade Bear Caulk is recommended.

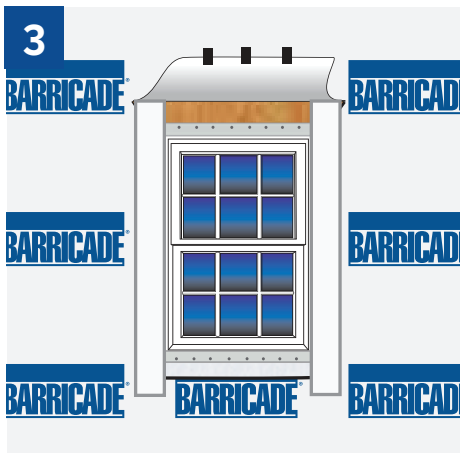

SIDE JAM FLASHING

Utilizing a roller to provide firm, consistent pressure, apply Barricade window flashing along vertical sides of the opening. Flash over the side window flanges. Extend the flashing a minimum of 3" beyond the sill flashing already in place and extend the flashing you're using a minimum of 3" beyond the top of the opening, so that it projects beyond the head flashing to be applied later.

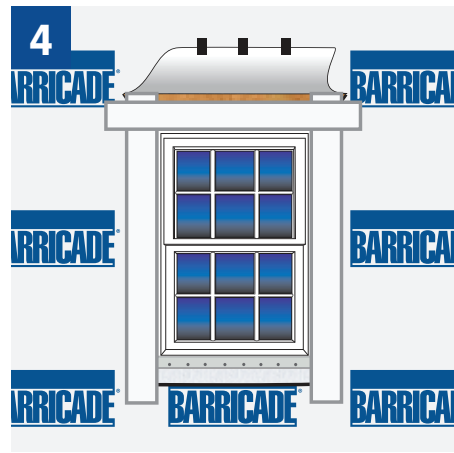
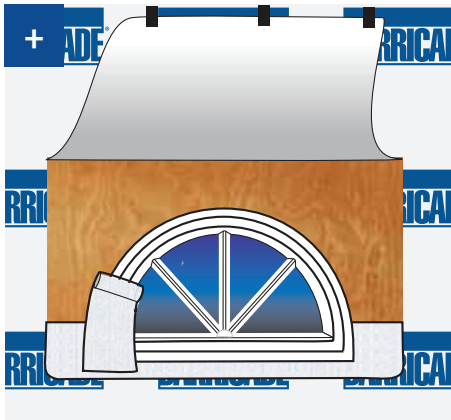

HEAD FLASHING

Affix the bottom of the head flashing over the mounting flange. Be sure to extend the flashing beyond each jamb flashing. Secure in place by applying pressure. Unattach house wrap and apply over head flashing as shown. Tape all seams and joints.

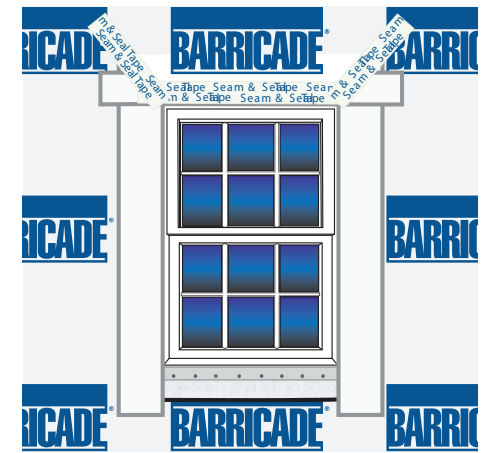

CIRCULAR WINDOWS

Follow above instructions for proper installation prior to head flashing installation. Install circular-top windows according to window manufacturers installation guidelines, then follow instructions below to complete the process.

Measure the circular portion of the window and add 12" to this number. Cut flashing to this length for the head flashing. Remove approximately 20" of release paper and position flashing tightly along the first edge of round window; press firmly into place.

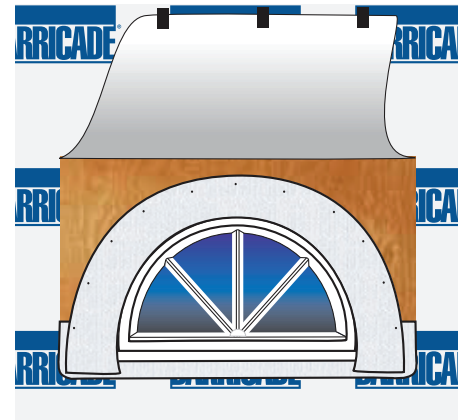

Continue removing release paper and conform Barricade Flash Conform along entire circular portion of window. Use Barricade Seam Tape or mechanical fasteners (i.e. nails, staples, or screws) to temporarily hold top edge of head flashing to wall. Flash Conform's adhesive bond will strengthen over time. Both ends of head flashing should overlap jamb flashings by at least 6".

Note:

This recommendation refers to the most commonly used types of windows (surface mounted). For other types of frames, special attention should be paid to window manufacturer instructions.



PREPARATORY WORK

A spray adhesive, such as Nashua 357, is recommended when Barricade Flash Corners are applied directly to Oriented Strand Board (OSB) or other surfaces where additional adhesion is needed or required.

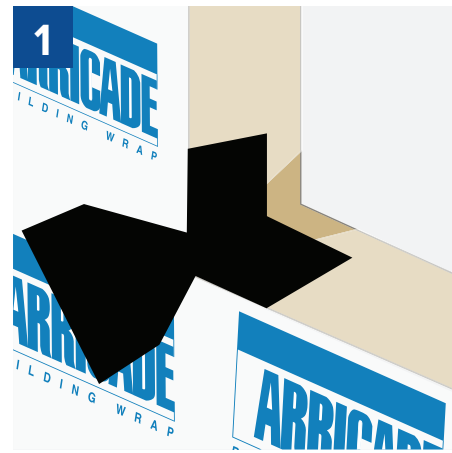

Peel back paper-release liner and discard. Adhere square-edged side of Barricade Flash Corners to a front, inside sill corner. Ensure the front edge of the material is flush with the front edge of the window opening.

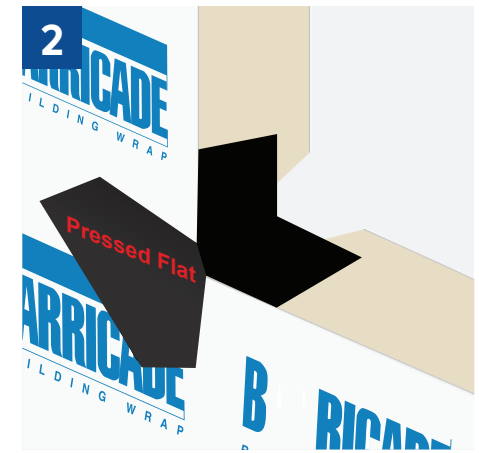

Smooth the dove-tailed edge of the Flash Corners over the sill and adhere to the vertical wall face. Make certain any bubbles or wrinkles are smoothed out.

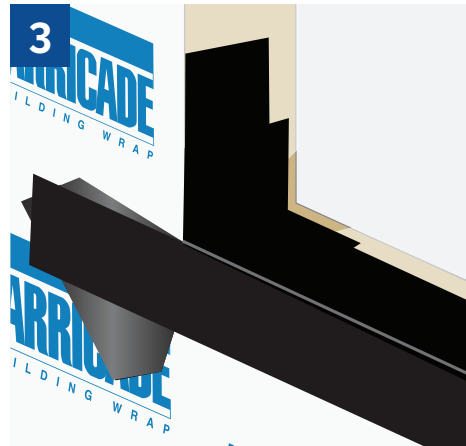

Repeat Steps 1-3 for the other corner of the window. Overlap the horizontal flanges of Barricade Flash Corners with a measured piece of Barricade Flash Ulti or Barricade Flash Extreme window flashing. Flash remaining portion of window per the building code.

IMPORTANT TO NOTE

Avoid contact with residual asphaltic products (mastics or primers), such as coatings and other roofing products. 15-pound felt paper or building paper may be used with Barricade Flash Corners. Make sure overlaps are in the direction of moisture drainage.

FLASHING PENETRATIONS

WHEN INSTALLED
UNDER THE HOUSE WRAP

SQUARE PENETRATION

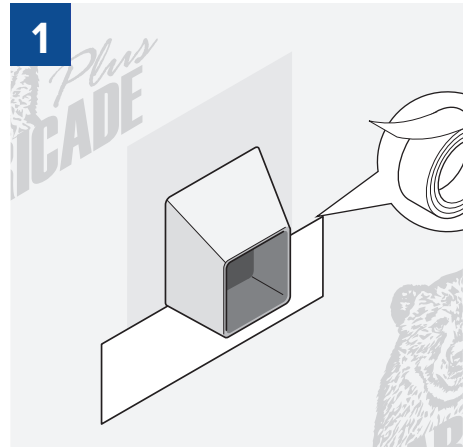

1 Apply flashing to the bottom of the penetration. We recommend using Barricade Flash Ulti, Barricade Flash Extreme, or Barricade Flash Right.

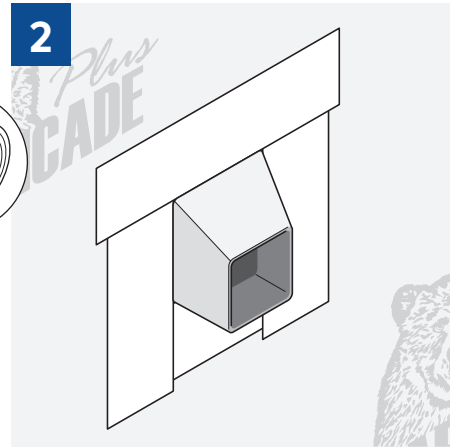

2 Apply flashing along the sides and then the top, shingling each layer.

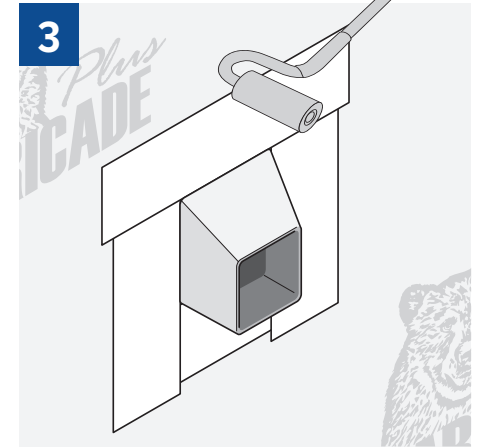

3 Use a roller to apply even pressure along the flashing, being sure to push out any air pockets that may have appeared. Barricade suggests finishing with Barricade Bear Caulk commercial sealant to ensure a tight seal around the edges of the penetration.

ROUND PENETRATION

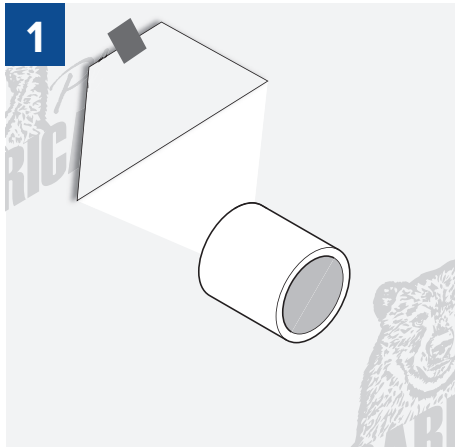

1 Cut two 45° angles and peel back house wrap above the penetration.

Tip: Use Barricade Seam Tape to hold the flap up while not in use.

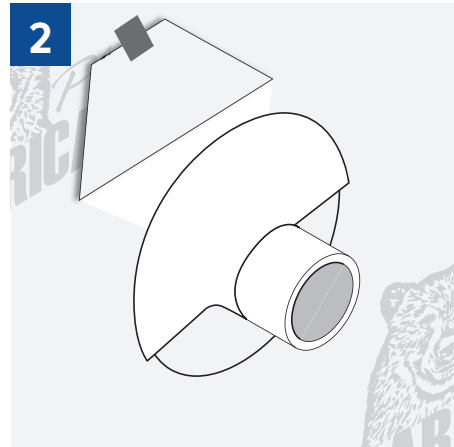

2 Apply Barricade Flash Conform to the underside of penetration, shingling the above side after. Use a roller to apply even pressure along the flashing.

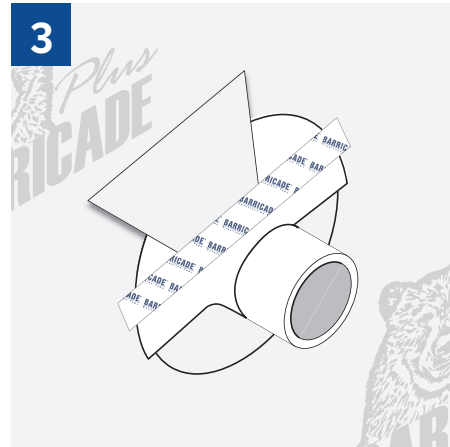

3 Replace house wrap flap over the flashing and tape across using Barricade Seam Tape.

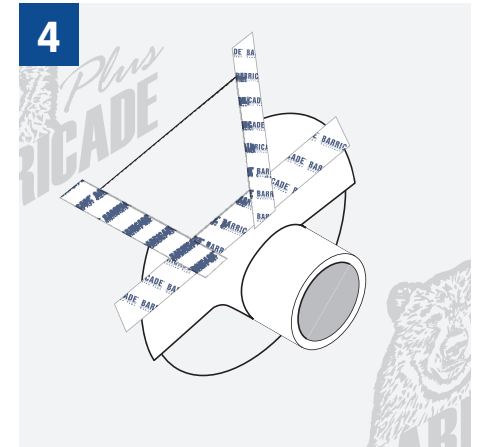

4 Tape over the 45° cuts using Barricade Seam Tape.

FLASHING PENETRATIONS

WHEN INSTALLED
OVER THE HOUSE WRAP

SQUARE PENETRATION

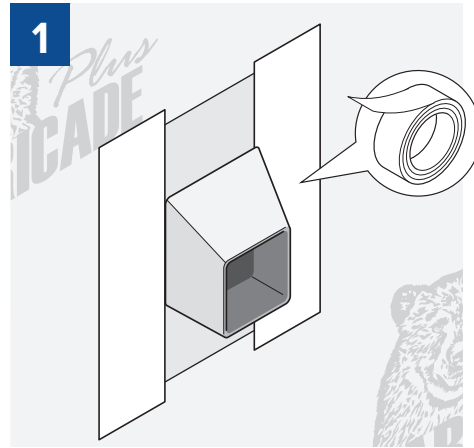

1 Apply flashing along the sides first, leaving the bottom unflashed. We recommend using Barricade Flash Ulti, Barricade Flash Extreme, or Barricade Flash Right.

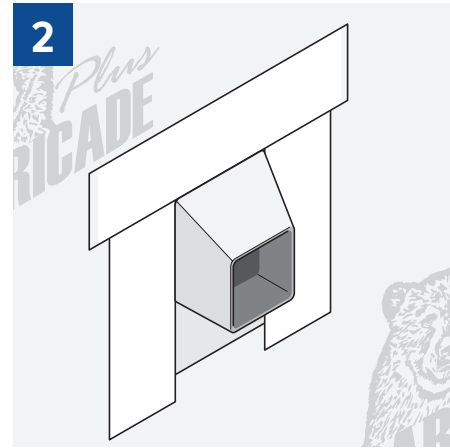

2 Next apply flashing over the top, shingling the side flashing.

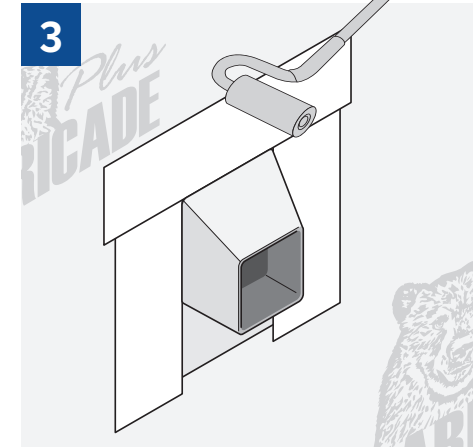

3 Use a roller to apply even pressure along the flashing, being sure to push out any air pockets that may have appeared. Barricade suggests finishing with Barricade Bear Caulk commercial sealant to ensure a tight seal around the edges of the penetration.

OTHER DETAILS:

All installation instructions and procedures contained within this brochure are recommended by Barricade Building Products and should be followed. Failure to follow these instructions and procedures may compromise the integrity of the building wrap and impact its performance.

Barricade house wraps are backed by a 10-year limited warranty. Please contact Barricade Building Products for more information.

All Barricade Building Products building wrap is manufactured to meet the full intent of all applicable building codes and their governing bodies.

Barricade is a weather-resistive barrier (WRB) designed to provide a secondary line of defense against bulk water penetration. It is not designed or intended for use as a primary waterproofing membrane.

Wind-driven rain can penetrate exterior sidings/cladding such as vinyl, wood, brick, aluminum, hardboard, cementitious, etc. Vinyl and aluminum siding are manufactured with built-in weep holes to allow proper drainage of water that gets past it. Wood, hardboard,

and brick exteriors are porous, allowing water to be absorbed into them. Most brick facades also have weep holes built into the wall system to promote water drainage.

Contamination of Barricade Building Products building wrap and various building site chemicals or various sugars and saps found in wood sidings (e.g. cedar) which increase its wettability (e.g. surfactants), will adversely affect the house wrap's water-resistive capability and its contribution to the overall water resistance of the wall system. Surfactants can be defined as substances which adversely impact and contaminate the surface tension of a given house wrap or building paper by raising their surface energy which allows liquid to "wet" the surface more easily. Where wood sidings, such as cedar, are concerned, it is strongly recommended that both priming or back coating of the siding be performed. This helps isolate the surfactants in the wood from the house wrap or building paper surface. In addition to back priming/coating, an airspace should also be created between the siding and house wrap. Providing some form of airspace between the wood trim, siding, and clapboards and the house wrap using furring or some other

form of spacer reduces the quantity and time liquid phase for any water that is trapped in the exterior wall assembly, thereby reducing the potential for surfactant movement.

Any rips, tears, breaks, holes, etc. that happen during normal construction should be repaired by taping or patching. Other holes, gaps, or cracks created in the exterior wall around items such as faucets, dryer vents, electrical outlets, etc. should also be properly taped, flashed, and sealed. Any of these occurrences that go unrepaired will diminish the building wrap's performance and contribution to the overall water-resistance of the wall system.

Standard fasteners, such as nails and staples, used to apply Barricade can reduce the building wraps water-resistive characteristics. Barricade Building Products encourages the use of plastic cap nails to improve the seal around the fastener and enhance the protection against water penetration at the fastener location.

All horizontal overlaps of building wrap must be at least 2" and vertical overlaps must at least be 6". Porous sidings such as brick, wood, hardboard and some

others allow water penetration and have the ability to store water due to their hygroscopic nature.

It's always a wise construction practice to use and integrate properly installed flashings around all window and door openings as well as other exterior penetrations as part of an overall design strategy to control moisture movement and transport. Please contact your builder or Barricade Building Products for more details.

The information contained in this installation guide is to the best of our knowledge, true and accurate and is presented in good faith. Barricade Building Products assumes no liability, expressed or implied as to the architecture, engineering, or workmanship of any project. This information may be concurrent with, or superseded by other applicable documents.

Contact Barricade Building Products for further information or technical support at 877-832-0333.

